

# Austrong Products

ALUMINUM SUN LOUVER 85C  
LAM CHẮN NẮNG AUSTRONG 85C

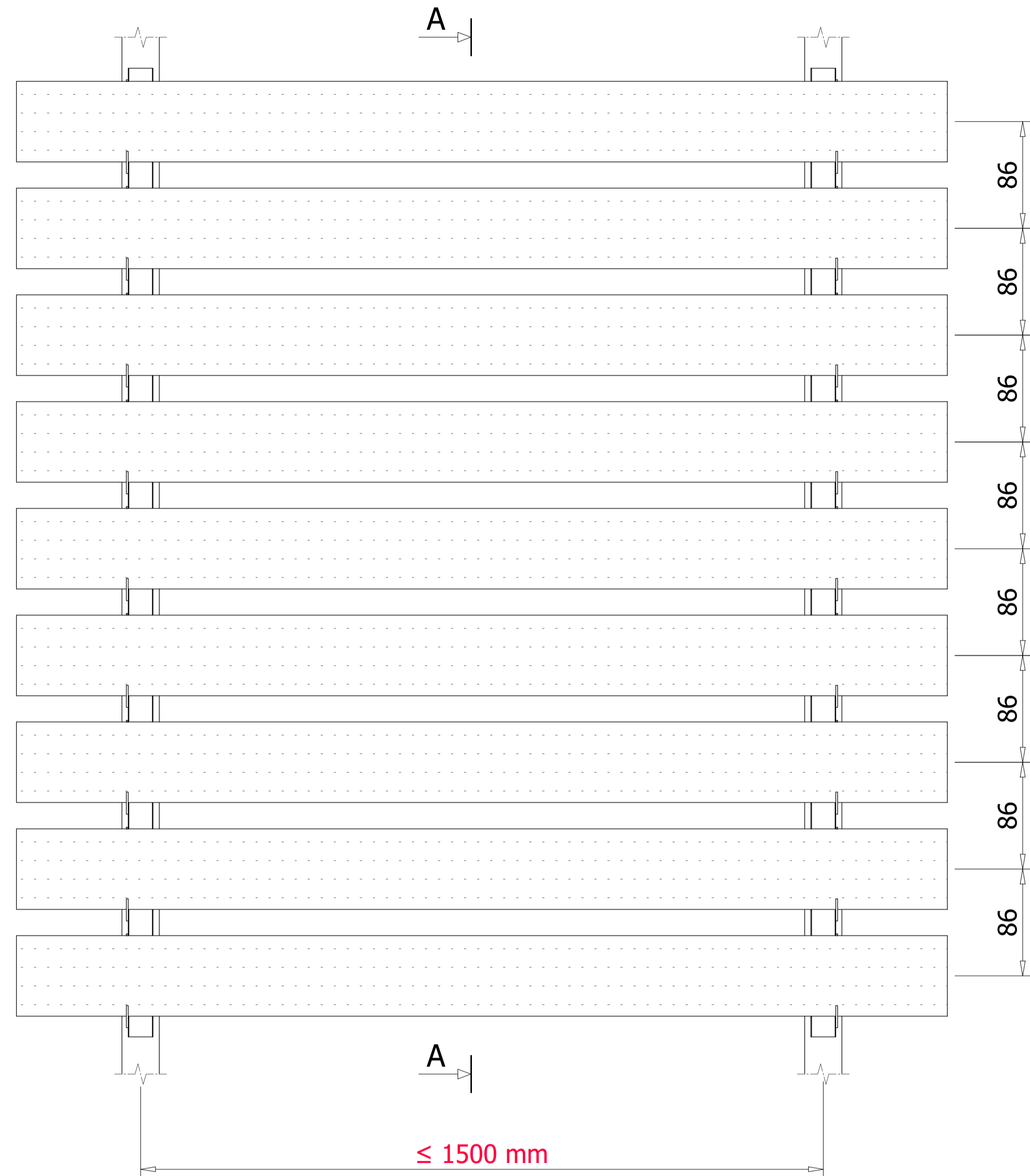

PANEL SECTION/ MẶT CẮT THANH LAM

SECTION/ MẶT CẮT: A - A

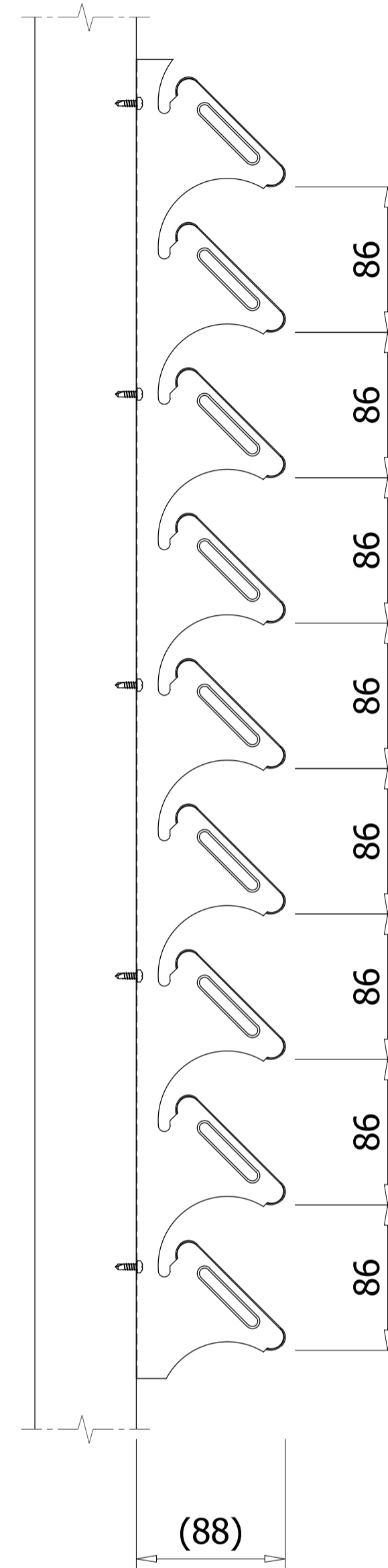

HORIZONTAL PROJECTION SYSTEM  
CẤU TẠO HỆ LAM THEO CHIỀU NGANG

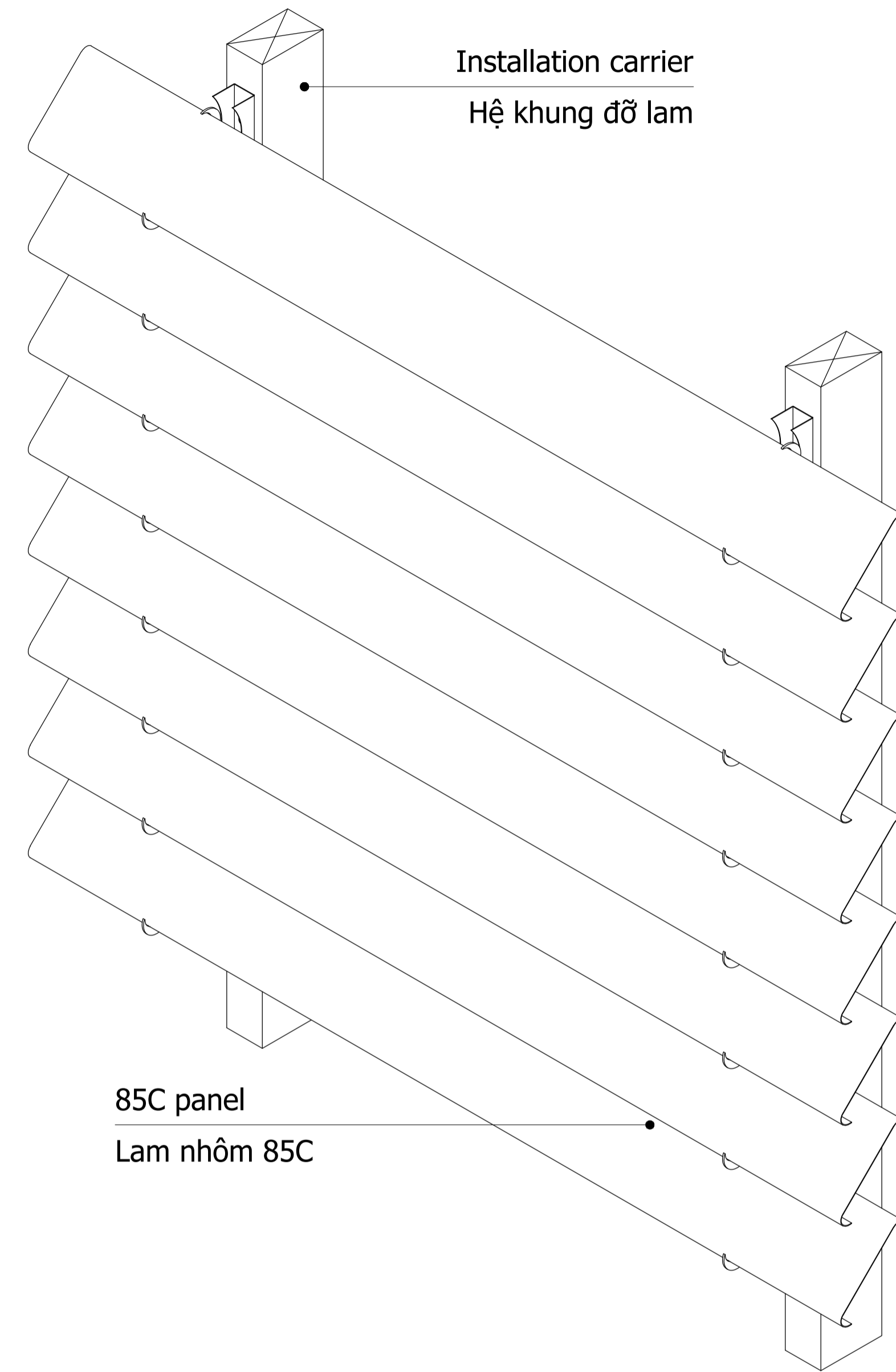

85C panel  
Lam nhôm 85C

INSTALLATION DETAIL/ CHI TIẾT LẮP ĐẶT

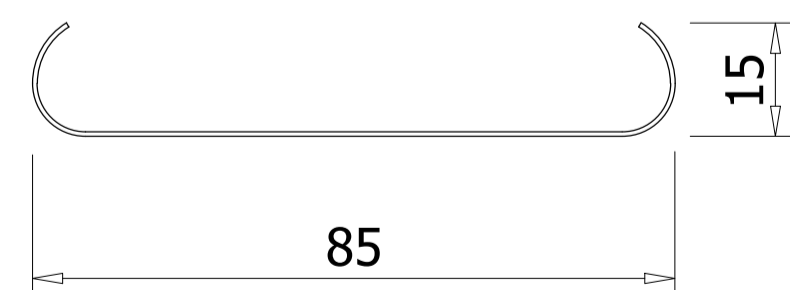

Specification/ Thông số kỹ thuật:

| Module | Thickness    | Length     |
|--------|--------------|------------|
| 85C    | 0.6 ÷ 0.8 mm | Customized |

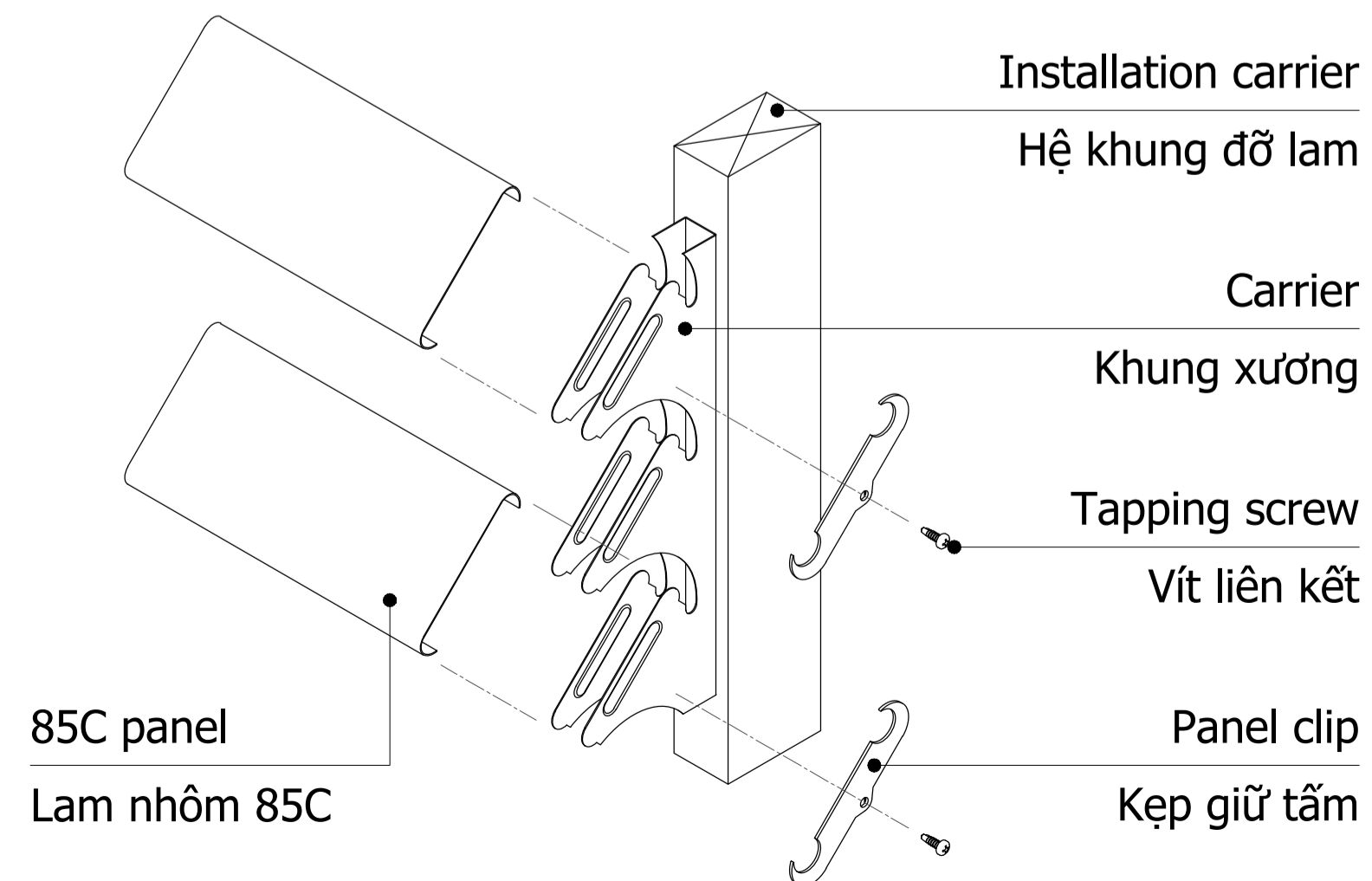

**Sun louver and carrier - Technical standards:**

- + Material panel: Aluminum alloy A3003 H14-H24  
Certificate: ASTM B209/B209M-21a
- + Carrier material: Galvanized steel  
(Powder coated color upon request)
- + Panel surface treatment : Polyester paint or powder coating  
(color upon request)

**Lam chắn nắng và khung xương - Tiêu chuẩn kỹ thuật:**

- + Vật liệu tấm lam: Nhôm hợp kim mác A3003 H14-H24  
Chứng nhận đạt tiêu chuẩn: ASTM B209/B209M-21a
- + Khung xương trần: Thép mạ kẽm  
(Có thể sơn tĩnh điện theo yêu cầu)
- + Bề mặt hoàn thiện: Sơn polyester (PE) hoặc sơn tĩnh điện  
(màu theo yêu cầu)

| Revisions |       |             |
|-----------|-------|-------------|
| No        | Date  | Description |
| ....      | ..... | .....       |
| ....      | ..... | .....       |
| ....      | ..... | .....       |
| ....      | ..... | .....       |
| ....      | ..... | .....       |
| ....      | ..... | .....       |
| ....      | ..... | .....       |
| ....      | ..... | .....       |

Owner: .....

Project: .....

Category: .....

Location: .....

Contractor: **Austrong Group**   
**Ceiling - Sun Louver - Façade**  
 Hanoi - Office: No 49 Ln 15 An Duong Vuong Road, Phu Thuong Ward, Tay Ho District, Hanoi City, Vietnam  
 Ho Chi Minh - Office: No 73-75 S3 Road, Tay Thanh Ward, Tan Phu District, Ho Chi Minh City, Vietnam  
 Website: www.austrong.com.vn

| Function | Name              | Signature |
|----------|-------------------|-----------|
| Approved | .....             |           |
| Checked  | Nguyễn Trung Kiên |           |
| Designed | Nguyễn Trung Kiên |           |

Title Drawing: **BẢN VẼ SƠ BỘ**  
**HỆ LAM 85C**

| Scale       | .....   | Format       |
|-------------|---------|--------------|
| Date        | 01/2024 | A3 (420x297) |
| Drawing No. | .....   |              |

 This drawing is copyright by AUSTRONG GROUP